



TECHNICAL GUIDE

MODULAR VARIABLE SPEED ECM COMMUNICATING AIR HANDLERS

FOR USE WITH SPLIT-SYSTEM COOLING & HEAT PUMPS

MODELS: MVC SERIES



ISO 9001
Certified Quality
Management System



DESCRIPTION

This unique modular system allows the flexibility to handle any application. These versatile MVC blowers may be used for upflow, downflow, or horizontal left or right applications. They may be combined with cased coils to function as a cooling only unit or with a heat pump including electric heat for 1 and 3 phase applications.

FEATURES

COMMON MVC AIR HANDLER AND MATCH-UP CM COIL

Rigid Case Construction - An interior endoskeleton for structural support, smooth side, and locks in insulation.

Powder-painted - G30 galvanized steel case provide a coated edge that resists corrosion and rust creep.

Quality Construction - Structural components are made of Aluminum or G90 galvanized steel to prevent corrosion.

Improved Insulation Design - Single piece with no external screws to reduce thermal transmission paths to prevent sweating. Foil faced insulation for ease of cleaning.

Case Depth - These models have 20.5" casing which provide ease of attic access and tight applications.

MVC AIR HANDLERS

Factory Sealed - Achieves 2% or less total airflow leakage rate at duct leakage test conditions in positive and negative pressure for system airflow verification.

Electric Heat Kits - 6HK series of field installed electric heat kits are available for installation-friendly and easy service applications.

Blowers - All models use direct-drive, variable speed ECM motors.

CM COILS

MaxAlloy™ Coil - Long life aluminum coils built to deliver lasting performance, efficiency and reliability.

Thermostatic Expansion Valve - The accessory bolt-on TXV provides easy installation to convert the indoor coil to the required refrigerant that does not require brazing to replace or install. Some models are available with factory installed TXV.

Thermoset Drain Pan - Low retention and positive slope for drainage to reduce potential mold or contaminants.

Accessories - A full line of matching accessories available for use with the blower and coils to provide for any type of application.

Due to continuous product improvement, specifications are subject to change without notice.

Visit us on the web at:

www.upgnet.com and www.york.com

Additional rating information can be found at:

www.ahridirectory.org

WARRANTY SUMMARY

Standard 5-year limited parts warranty.

Extended 10-year limited parts warranty when product is registered online within 90 days of purchase for replacement or closing for new home construction.

LIST OF SECTIONS

DESCRIPTION 1
 FEATURES 1
 NOMENCLATURE 2
 DIMENSIONS & DUCT CONNECTION DIMENSIONS 3
 DIMENSIONS - MVC MODULAR AIR HANDLERS &
 CM MULTI-POSITION FULL CASED COILS 3
 COOLING CAPACITY 5
 PHYSICAL & ELECTRICAL DATA - COOLING ONLY 6
 kW & MBH CONVERSIONS - FOR
 TOTAL POWER INPUT REQUIREMENT 6
 APPLICATION FACTORS - RATED CFM VS. ACTUAL CFM 7
 ELECTRICAL DATA - COOLING ONLY 7
 ELECTRICAL HEAT - MINIMUM FAN SPEED 7
 ELECTRIC HEAT PERFORMANCE DATA: 208/230-1-60 &
 208/230-3-60 7
 ELECTRICAL DATA FOR
 SINGLE SOURCE POWER SUPPLY: 208/230-1-60 8
 ELECTRICAL DATA FOR
 MULTI-SOURCE POWER SUPPLY: 208/230-1-60 9
 ELECTRICAL DATA FOR
 SINGLE SOURCE POWER SUPPLY: 208/230-3-60 9
 ELECTRICAL DATA FOR
 MULTI-SOURCE POWER SUPPLY: 208/230-3-60 10
 POWER WIRING - LINE CONNECTIONS 10
 ACCESSORIES 10
 FILTER RACK DIMENSIONS 11
 LIMITATIONS 11
 COMBUSTIBLE FLOOR BASE ACCESSORY 11
 TYPICAL THERMOSTAT CONNECTION 12
 AIR FLOW DATA - CFM 13

NOMENCLATURE

PRODUCT TYPE	M	M = Modular Blower
POSITION MOTOR TYPE	V	P = Multi PSC E = Multi Std ECM V = Multi VS ECM
OPTIONS	C	C = Communications Ready - (No Designator) = Standard (No Options)
NOMINAL AIR FLOW	12	08 = 800 CFM 12 = 1,200 CFM 14 = 1,400 CFM 16 = 1,600 CFM 20 = 2,000 CFM
CABINET WIDTH	B	A = 14.5" B = 17.5" C = 21.0" D = 24.5"
OPTIONS	N	N = No options
VOLTAGE (Voltage-Phase-Hertz)	2	1 = 115-1-60 3 = 208/230-3-60 2 = 208/230-1-60 4 = 460-3-60
GENERATION (MAJOR REVISION)	1	1 = 1st Gen 2 = 2nd Gen etc.
STYLE LETTER (MINOR REVISION) NOT USED FOR ORDERING	A	A = Style A B = Style B etc.

DIMENSIONS & DUCT CONNECTION DIMENSIONS

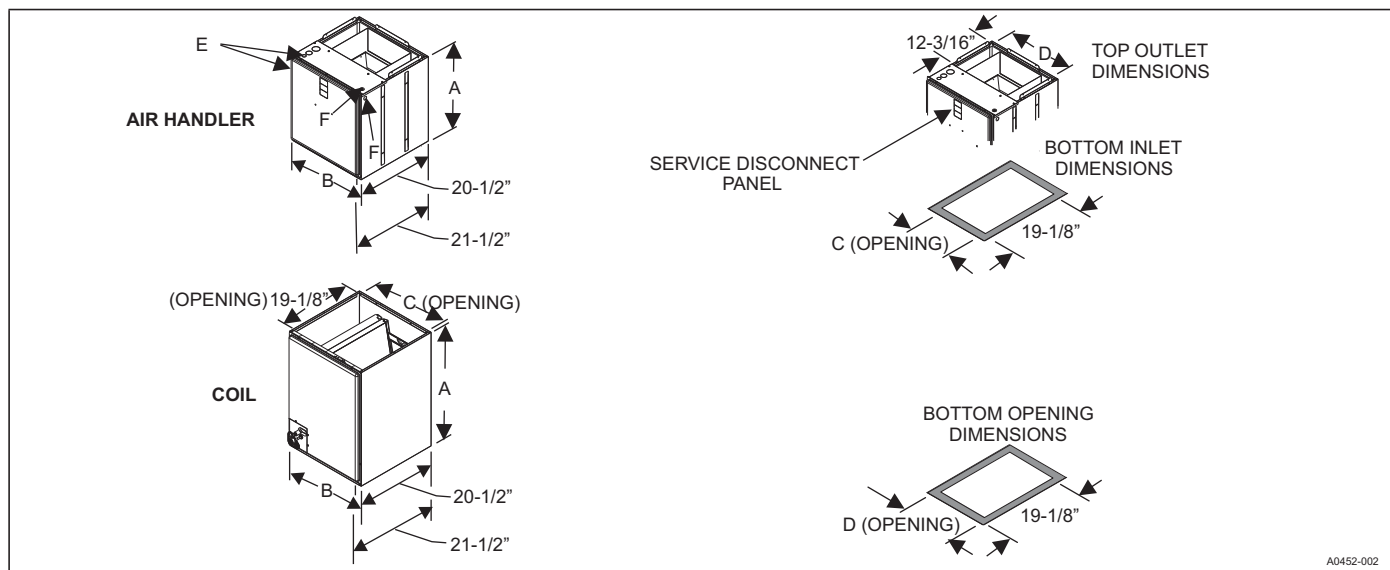

DIMENSIONS - MVC MODULAR AIR HANDLERS & CM MULTI-POSITION FULL CASED COILS

Models	Dimensions (inches)						Models	Dimensions (in.)	
	Height A	Width B	Opening Widths		Wiring Knockouts			Height A	Width B
			C	D	E Power	F Control			
MVC08BN21	21-1/2	17-1/2	16-1/2	16-1/2	7/8 (1/2), 1-3/8 (1), 1-23/32 (1-1/4)	7/8 (1/2)	MVC08BN21	21-1/2	17-1/2
MVC12BN21	21-1/2	17-1/2	16-1/2	16-1/2			MVC12BN21	21-1/2	17-1/2
MVC14DN21	22-1/2	24-1/2	23-1/2	23-1/2			MVC14DN21	22-1/2	24-1/2
MVC16CN21	22-1/2	21	20	20			MVC16CN21	22-1/2	21
MVC20DN21	22-1/2	24-1/2	23-1/2	23-1/2			MVC20DN21	22-1/2	24-1/2
Model	Dimensions (inches)				Weight (lbs)		Metering Device	Refrigerant ¹ Connections	
	Tall A	Wide B	Opening Width		Ship	Operate		Line Size (in.)	
	C	D	Liquid	Vapor					
CM - Indoor Coil Multi-position MaxAlloy™ No Factory Installed Metering Device									
CM18AXA1	19-1/2	14-1/2	13-1/2	13-1/2	40	39	Flex	3/8	3/4
CM18BXA1	19	17-1/2	16-1/2	16-1/2	42	41	Flex		
CM24AXA1	19-1/2	14-1/2	13-1/2	13-1/2	43	42	Flex		
CM24BXA1	19	17-1/2	16-1/2	16-1/2	44	43	Flex		
CM24CXA1	21	21	20	20	45	44	Flex		
CM30AXA1	25-1/2	14-1/2	13-1/2	13-1/2	49	48	Flex		
CM30BXA1	23	17-1/2	16-1/2	16-1/2	52	51	Flex		
CM30CXA1	23	21	20	20	53	52	Flex		
CM30DXA1	25	24-1/2	23-1/2	23-1/2	54	53	Flex		
CM36AXA1	25-1/2	14-1/2	13-1/2	13-1/2	53	52	Flex		
CM36BXA1	25-5/8	17-1/2	16-1/2	16-1/2	55	54	Flex		
CM36CXA1	25	21	20	20	56	55	Flex		
CM36DXA1	25	24-1/2	23-1/2	23-1/2	63	62	Flex		
CM42CXA1	27	21	20	20	61	60	Flex		
CM42DXA1	27	24-1/2	23-1/2	23-1/2	64	63	Flex		
CM48CXA1	33	21	20	20	65	64	Flex		
CM48DXA1	32-3/4	24-1/2	23-1/2	23-1/2	67	66	Flex		
CM60CXA1	33	21	20	20	75	74	Flex		
CM60DXA1	32-3/4	24-1/2	23-1/2	23-1/2	77	76	Flex		
CM64DXA1	32-3/4	24-1/2	23-1/2	23-1/2	83	82	Flex		

Continued on next page.

DIMENSIONS - MVC MODULAR AIR HANDLERS & CM MULTI-POSITION FULL CASED COILS

CM - Indoor Coil Multi-position MaxAlloy™ Factory Installed TXV Coils									
CM18ABAA1	19-1/2	14-1/2	13-1/2	13-1/2	42	41	FM TXV	3/8	3/4
CM24ABAA1	19-1/2	14-1/2	13-1/2	13-1/2	44	43	FM TXV		
CM24BBAA1	19	17-1/2	16-1/2	16-1/2	45	44	FM TXV		
CM30ABBA1	25-1/2	14-1/2	13-1/2	13-1/2	50	49	FM TXV		
CM30BBBA1	23	17-1/2	16-1/2	16-1/2	52	51	FM TXV		
CM30BBHA1	23	17-1/2	16-1/2	16-1/2	52	51	FM TXV		
CM36BBCA1	25-5/8	17-1/2	16-1/2	16-1/2	56	55	FM TXV		
CM36CBCA1	25	21	20	20	57	56	FM TXV		
CM42CBAA1	27	21	20	20	62	61	FM TXV		
CM42CBCA1	27	21	20	20	62	61	FM TXV		
CM48CBBA1	33	21	20	20	68	67	FM TXV		
CM48CBCA1	33	21	20	20	68	67	FM TXV		
CM48DBCA1	32-3/4	24-1/2	23-1/2	23-1/2	69	68	FM TXV		
CM60CBDA1	33	21	20	20	78	77	FM TXV		
CM60CBGA1	33	21	20	20	78	77	FM TXV		
CM60DBDA1	32-3/4	24-1/2	23-1/2	23-1/2	80	79	FM TXV		
CM - Indoor Coil Multi-position MaxAlloy™ Factory Installed EEV Coils									
CM25BE1A1	25-5/8	17-1/2	16-1/2	16-1/2	56	55	FM EEV	3/8	3/4
CM37BE2A1	25-5/8	17-1/2	16-1/2	16-1/2	57	56	FM EEV		
CM37CE2A1	25	21	20	20	57	56	FM EEV		
CM38BE2A1	25-5/8	17-1/2	16-1/2	16-1/2	57	56	FM EEV		
CM38CE2A1	25	21	20	20	57	56	FM EEV		
CM49CE3A1	33	21	20	20	76	75	FM EEV		
CM49DE3A1	32-3/4	24-1/2	23-1/2	23-1/2	78	77	FM EEV		
CM50CE3A1	37-1/4	21	20	20	81	80	FM EEV		
CM50DE3A1	27-1/4	24-1/2	23-1/2	23-1/2	81	80	FM EEV		
CM61CE4A1	37-1/4	21	20	20	81	80	FM EEV		
CM61DE4A1	37-1/4	24-1/2	23-1/2	23-1/2	81	80	FM EEV		
									7/8

1. See outdoor unit technical guide for proper line set size.

COOLING CAPACITY¹

Models	Rated CFM ²	Entering Air Dry/Wet Bulb (°F)	MBH@ Evap. Temp. and Corresponding R-410A Pressure (°F/PSIG)			
			35/107.9	40/118.9	45/130.7	50/143.3
CM18B	600	85/72	45.7	41.6	36.8	30.5
		80/67	38.5	33.9	28.5	22.3
		75/62	31.5	26.5	20.5	15.9
		70/57	24.4	19.5	15.2	11.5
CM24B	800	85/72	52.2	47.5	41.8	35.0
		80/67	43.6	38.3	31.9	24.5
		75/62	35.2	29.5	22.7	16.2
		70/57	27.1	20.7	15.5	11.4
CM24C	800	85/72	52.2	47.5	41.8	35.0
		80/67	43.6	38.3	31.9	24.5
		75/62	35.2	29.5	22.7	16.2
		70/57	27.1	20.7	15.5	11.4
CM30B	1000	85/72	75.3	67.8	56.8	47.1
		80/67	62.6	54.6	44.2	34.5
		75/62	50.2	41.3	32.0	22.9
		70/57	37.8	30.1	21.5	16.2
CM30C	1000	85/72	75.3	67.8	56.8	47.1
		80/67	62.6	54.6	44.2	34.5
		75/62	50.2	41.3	32.0	22.9
		70/57	37.8	30.1	21.5	16.2
CM30D	1000	85/72	75.3	67.8	56.8	47.1
		80/67	62.6	54.6	44.2	34.5
		75/62	50.2	41.3	32.0	22.9
		70/57	37.8	30.1	21.5	16.2
CM36B	1000	85/72	82.1	73.7	64.1	54.4
		80/67	68.6	60.1	50.5	39.5
		75/62	56.3	47.0	37.3	29.2
		70/57	43.5	36.0	28.3	21.6
CM36B	1200	85/72	91.6	82.4	71.3	59.4
		80/67	76.5	65.4	54.6	42.8
		75/62	61.3	51.2	40.0	30.5
		70/57	47.5	38.1	28.7	22.3
CM42C	1200	85/72	98.0	88.6	77.4	66.4
		80/67	82.6	72.6	61.7	50.6
		75/62	68.5	57.6	47.5	36.6
		70/57	53.9	44.8	35.0	28.4
CM36C	1200	85/72	91.6	82.4	71.3	59.4
		80/67	76.5	65.4	54.6	42.8
		75/62	61.3	51.2	40.0	30.5
		70/57	47.5	38.1	28.7	22.3
CM36D	1200	85/72	91.6	82.4	71.3	59.4
		80/67	76.5	65.4	54.6	42.8
		75/62	61.3	51.2	40.0	30.5
		70/57	47.5	38.1	28.7	22.3
CM42C	1400	85/72	100.6	89.8	78.2	64.7
		80/67	83.5	73.7	59.8	48.0
		75/62	67.8	55.8	44.7	32.5
		70/57	52.3	41.5	30.7	23.7
CM42D	1400	85/72	100.6	89.8	78.2	64.7
		80/67	83.5	73.7	59.8	48.0
		75/62	67.8	55.8	44.7	32.5
		70/57	52.3	41.5	30.7	23.7

COOLING CAPACITY¹ (Continued)

Models	Rated CFM ²	Entering Air Dry/Wet Bulb (°F)	MBH@ Evap. Temp. and Corresponding R-410A Pressure (°F/PSIG)			
			35/107.9	40/118.9	45/130.7	50/143.3
CM48C	1400	85/72	108.0	98.4	88.1	73.8
		80/67	93.3	82.1	69.7	57.0
		75/62	75.9	64.4	53.1	41.9
		70/57	60.7	49.9	39.4	32.4
CM48C	1600	85/72	115.2	105.0	93.9	79.0
		80/67	88.3	78.2	65.5	52.6
		75/62	72.7	60.8	50.1	37.6
		70/57	57.7	46.9	36.6	29.7
CM48D	1600	85/72	115.2	105.0	93.9	79.0
		80/67	88.3	78.2	65.5	52.6
		75/62	72.7	60.8	50.1	37.6
		70/57	57.7	46.9	36.6	29.7
CM60C	1800	85/72	115.1	103.0	91.7	78.6
		80/67	96.8	85.9	73.7	60.5
		75/62	80.7	69.4	57.5	43.5
		70/57	58.7	48.9	37.7	32.7
CM60D	1800	85/72	115.1	103.0	91.7	78.6
		80/67	96.8	85.9	73.7	60.5
		75/62	80.7	69.4	57.5	43.5
		70/57	58.7	48.9	37.7	32.7
CM64D	1800	85/72	133.6	118.5	103.2	86.6
		80/67	111.4	96.2	80.3	62.8
		75/62	90.7	75.1	60.0	43.5
		70/57	70.6	56.9	42.5	32.8

For notes, see Page 5.

1. See Condensing Unit or Heat Pump Technical Guide for Total Cooling Capacity and Sensible Capacity.
2. Airflow is calculated for each system tonnage.

PHYSICAL & ELECTRICAL DATA - COOLING ONLY

Models		MVC08B	MVC12B	MVC14D	MVC16C	MVC20D
Blower - Diameter x Width		10 x 8	10 x 8	11 x 10	11 x 10	11 x 10
Motor	HP	1/3 HP	1/2 HP	1/2 HP	3/4 HP	3/4 HP
	Nominal RPM	1050	1050	1050	1050	1050
Voltage		208/230	208/230	208/230	208/230	208/230
Full Load Amps @230V		2.9	4.5	4.5	7.0	7.0
Filter ¹	Type	DISPOSABLE OR PERMANENT				
	Size	16 x 20 x 1	16 x 20 x 1	22 x 20 x 1	20 x 20 x 1	22 x 20 x 1
	Bottom Rack Kit	1BR01117	1BR01117	1BR01124	1BR01121	1BR01124
	Permanent Type Kit	1PF0601	1PF0601	1PF0603	1PF0602	1PF0603
Shipping / Operating Weight (lbs.)		52/51	52/51	75/74	68/67	75/74

1. Field Supplied.

kW & MBH CONVERSIONS - FOR TOTAL POWER INPUT REQUIREMENT

For a power distribution voltage that is different than the provided nominal voltage, multiply the kW and MBH data from the table by the conversion factor in the following table.

DISTRIBUTION POWER	NOMINAL VOLTAGE	CONVERSION FACTOR
208V	240V	0.75
220V	240V	0.84
230V	240V	0.92

APPLICATION FACTORS - RATED CFM VS. ACTUAL CFM

% Of Rated Airflow (CFM)	80%	90%	100%	110%	120%
Capacity Factor	0.96	0.98	1.00	1.02	1.03

ELECTRICAL DATA - COOLING ONLY

Models	Motor FLA ¹		Minimum Circuit Ampacity		MOP ²
	208V	230V	208V	230V	
MVC08B	3.0	2.9	3.8	3.6	15
MVC12B/MVC14D	5.0	4.5	6.3	5.6	
MVC16C/MVC20D	7.3	7.0	9.1	8.8	

1. FLA = Full Load Amps.

2. MOP = Maximum Overcurrent Protection device; must be HACR type circuit breaker or time delay fuse. Refer to the latest edition of the National Electric Code or in Canada the Canadian electrical Code and local codes to determine correct wire sizing.

ELECTRICAL HEAT - MINIMUM FAN SPEED

Heater Kit Models ^{1,2,3}	Nom. kW @240V	Air Handler Models				
		MVC08B	MVC12B	MVC14D	MVC16C	MVC20D
6HK(0,1)6500206	2.4kW	Med Lo (D)	Med Lo (D)	Med Lo (D)	Med Lo (D)	Med Lo (D)
6HK(0,1)6500506	4.8kW	Med (C)	Med Lo (D)	Med Lo (D)	Med Lo (D)	Med Lo (D)
6HK(0,1)6500806	7.7kW	Med Hi (B)	Med Lo (D)	Med (C)	Med Lo (D)	Med Lo (D)
6HK(0,1)6501006 6HK36501025	9.6kW	Med Hi (B)	Med Lo (D)	Med (C)	Med Lo (D)	Med Lo (D)
6HK(1,2)6501306	12.5kW	Hi (A)	Med Hi (B)	Med (C)	Med Lo (D)	Med Lo (D)
6HK(1,2)6501506 6HK36501525	14.4kW	–	Hi (A)	Med (C)	Med Lo (D)	Med Lo (D)
6HK(1,2)6501806 6HK36501825	17.3kW	–	Hi (A)	Med Hi (B)	Med (C)	Med (C)
6HK(1,2)6502006 6HK46502025	19.2kW	–	Hi (A)	–	Med Hi (B)	Med (C)
6HK(1,2)6502506 6HK46502525	24kW	–	–	–	–	Med (C)

1. (0,1) - 0 = no service disconnect OR 1 = with service disconnect.

2. (1,2) - 1 = with service disconnect, no breaker jumper bar OR 2 = with service disconnect & breaker jumper bar.

3. 6HK3 = 3-Phase with terminal block connectors only, 6HK4 = 3-Phase with service disconnect.

ELECTRIC HEAT PERFORMANCE DATA: 208/230-1-60 & 208/230-3-60

Heater Models ^{1,2,3}		Nominal kW @240V	Total Heat ⁴				kW Staging			
			kW		MBH		W1 Only		W1 + W2	
			208V	230V	208V	230V	208V	230V	208V	230V
1PH	6HK(0,1)6500206	2.4	1.8	2.2	6.2	7.5	1.8	2.2	1.8	2.2
	6HK(0,1)6500506	4.8	3.6	4.4	12.3	15	3.6	4.4	3.6	4.4
	6HK(0,1)6500806	7.7	5.8	7.1	19.7	24.1	5.8	7.1	5.8	7.1
	6HK(0,1)6501006	9.6	7.2	8.8	24.6	30.1	7.2	8.8	7.2	8.8
	6HK(1,2)6501306	12.5	9.4	11.5	32	39.2	3.1	3.8	9.4	11.5
	6HK(1,2)6501506	14.4	10.8	13.2	36.9	45.1	3.6	4.4	10.8	13.2
	6HK(1,2)6501806	17.3	13	15.9	44.3	54.2	6.5	7.9	13	15.9
	6HK(1,2)6502006	19.2	14.4	17.6	49.2	60.2	7.2	8.8	14.4	17.6
3PH	6HK(1,2)6502506	24	18	22	61.5	75.2	7.2	8.8	18	22
	6HK36501025	9.6	7.2	8.8	24.6	30.1	7.2	8.8	7.2	8.8
	6HK36501525	14.4	10.8	13.2	36.9	45.1	10.8	13.2	10.8	13.2
	6HK36501825	17.3	13	15.9	44.3	54.2	13	15.9	13	15.9
	6HK46502025	19.2	14.4	17.6	49.2	60.2	7.2	8.8	14.4	17.6
	6HK46502525	24	18	22	61.5	75.2	9	11	18	22

1. (0,1) - 0 = no service disconnect OR 1 = with service disconnect.

2. (1,2) - 1 = with service disconnect, no breaker jumper bar OR 2 = with service disconnect & breaker jumper bar.

3. 6HK3 = 3-Phase with terminal block connectors only, 6HK4 = 3-Phase with service disconnect.

4. For different power distributions, see conversion table on Page 5.

ELECTRICAL DATA FOR SINGLE SOURCE POWER SUPPLY: 208/230-1-60

Air Handler Models	Heater Models ^{1,2}	Heater Amps @240V	Field Wiring			
			Min. Circuit Ampacity		MOP. ³	
			208V	230V	208V	230V
MVC08B	6HK(0,1)6500206	10	14.6	15.6	15	20
	6HK(0,1)6500506	20	25.4	27.5	30	30
	6HK(0,1)6500806	32	38.6	42.2	40	45
	6HK(0,1)6501006	40	47.0	51.5	50	60
	6HK(1,2)6501306	52	60.2	66.1	70	70
MVC12B	6HK(0,1)6500206	10	17.1	17.6	20	20
	6HK(0,1)6500506	20	27.9	29.5	30	30
	6HK(0,1)6500806	32	41.1	44.2	45	45
	6HK(0,1)6501006	40	49.5	53.5	50	60
	6HK(1,2)6501306	52	62.7	68.1	70	70
	6HK(1,2)6501506	60	71.2	77.4	80	80
	6HK(1,2)6501806	72	84.4	92.0	90	100
MVC14D	6HK(0,1)6500206	10	17.1	17.6	20	20
	6HK(0,1)6500506	20	27.9	29.5	30	30
	6HK(0,1)6500806	32	41.1	44.2	45	45
	6HK(0,1)6501006	40	49.5	53.5	50	60
	6HK(1,2)6501306	52	62.7	68.1	70	70
	6HK(1,2)6501506	60	71.2	77.4	80	80
	6HK(1,2)6501806	72	84.4	92.0	90	100
MVC16C	6HK(0,1)6500206	10	19.9	20.7	25	25
	6HK(0,1)6500506	20	30.8	32.7	35	35
	6HK(0,1)6500806	32	44.0	47.3	45	50
	6HK(0,1)6501006	40	52.4	56.6	60	60
	6HK(1,2)6501306	52	65.6	71.3	70	80
	6HK(1,2)6501506	60	74.0	80.5	80	90
	6HK(1,2)6501806	72	87.3	95.2	90	100
MVC20D	6HK(0,1)6500206	10	19.9	20.7	25	25
	6HK(0,1)6500506	20	30.8	32.7	35	35
	6HK(0,1)6500806	32	44.0	47.3	45	50
	6HK(0,1)6501006	40	52.4	56.6	60	60
	6HK(1,2)6501306	52	65.6	71.3	70	80
	6HK(1,2)6501506	60	74.0	80.5	80	90
	6HK(1,2)6501806	72	87.3	95.2	90	100
	6HK(1,2)6502006	80	95.7	104.4	100	110
	6HK(1,2)6502506	100	117.3	128.3	125	150

1. (0,1) - maybe 0 (no service disconnect) or 1 (with service disconnect).

2. (1,2) maybe 1 (with service disconnect, no breaker jumper bar) or 2 (with service disconnect & breaker jumper bar).

3. MOP = Maximum Overcurrent Protection device; must be HACR type circuit breaker or time delay fuse. Refer to the latest edition of the National Electric Code or in Canada the Canadian electrical Code and local codes to determine correct wire sizing.

ELECTRICAL DATA FOR MULTI-SOURCE POWER SUPPLY: 208/230-1-60

Air Handler Models	Heater Models	Heater Amps @240V	Min. Circuit Ampacity						MOP. ¹					
			208V			230V			208V			230V		
			Circuit						Circuit					
			1st ³	2nd	3rd	1st ³	2nd	3rd	1st ³	2nd	3rd	1st ³	2nd	3rd
MVC08B	6HK16501306	52	22.5	37.6	-	24.4	41.5	-	25	40	-	25	45	-
MVC12B	6HK16501306	52	25.0	37.6	-	26.4	41.5	-	25	40	-	30	45	-
	6HK16501506	60	27.9	43.3	-	29.6	47.9	-	30	45	-	30	50	-
	6HK16501806	72	45.3	39.0	-	48.8	43.1	-	50	40	-	50	45	-
	6HK16502006	80	49.6	43.3	-	53.5	47.9	-	50	45	-	60	50	-
MVC14D	6HK16501306	52	25.0	37.6	-	26.4	41.5	-	25	40	-	30	45	-
	6HK16501506	60	27.9	43.3	-	29.6	47.9	-	30	45	-	30	50	-
	6HK16501806	72	45.3	39.0	-	48.8	43.1	-	50	40	-	50	45	-
	6HK16502006	80	49.6	43.3	-	53.5	47.9	-	50	45	-	60	50	-
MVC16C	6HK16501306	52	27.9	37.6	-	29.5	41.5	-	30	40	-	30	45	-
	6HK16501506	60	30.8	43.3	-	32.7	47.9	-	35	45	-	35	50	-
	6HK16501806	72	48.1	39.0	-	51.9	43.1	-	50	40	-	60	45	-
	6HK16502006	80	52.5	43.3	-	56.7	47.9	-	60	45	-	60	50	-
MVC20D	6HK16501306	52	27.9	37.6	-	29.5	41.5	-	30	40	-	30	45	-
	6HK16501506	60	30.8	43.3	-	32.7	47.9	-	35	45	-	35	50	-
	6HK16501806	72	48.1	39.0	-	51.9	43.1	-	50	40	-	60	45	-
	6HK16502006	80	52.5	43.3	-	56.7	47.9	-	60	45	-	60	50	-
	6HK16502506	100	52.5	43.3	21.7	56.7	47.9	24.0	60	45	25	60	50	25

1. MOP = Maximum Overcurrent Protection device; must be HACR type circuit breaker or time delay fuse. The 1st circuit includes blower motor amps. Refer to the latest edition of the National Electric Code or in Canada the Canadian electrical Code and local codes to determine correct wire sizing.

ELECTRICAL DATA FOR SINGLE SOURCE POWER SUPPLY: 208/230-3-60

Air Handler Models	Heater Models ¹	Heater Amps @240V	Field Wiring			
			Min. Circuit Ampacity		MOP. ²	
			208V	230V	208V	230V
MVC08B	6HK36501025	23.1	28.8	31.3	30	35
MVC12B	6HK36501025	23.1	31.3	33.3	35	35
	6HK36501525	34.6	43.7	47.1	45	50
	6HK36501825	41.6	51.3	55.5	50	60
	6HK46502025*	46.2	56.3	61.0	60	70
MVC14D	6HK36501025	23.1	31.3	33.3	35	35
	6HK36501525	34.6	43.7	47.1	45	50
	6HK36501825	41.6	51.3	55.5	55	60
	6HK46502025*	46.2	59.2	64.1	60	70
MVC16C	6HK36501025	23.1	34.2	36.4	35	40
	6HK36501525	34.6	46.6	50.2	50	55
	6HK36501825	41.6	54.2	58.6	55	60
	6HK46502025*	46.2	59.2	64.1	60	70
MVC20D	6HK36501025	23.1	34.2	36.4	35	40
	6HK36501525	34.6	46.6	50.2	50	55
	6HK36501825	41.6	54.2	58.6	55	60
	6HK46502025*	46.2	59.2	64.1	60	70
	6HK46502525*	57.7	71.6	77.9	80	80

1. Asterisk (*) denotes the 20kW and 25kW heater models (6HK46502025 and 6HK46502525) come with service disconnects standard. Single source power MCA and MOP requirements are given here only for reference if used with field installed single point power modification (S1-32436041000).
2. MOP = Maximum Overcurrent Protection device; must be HACR type circuit breaker or time delay fuse. The 1st circuit includes blower motor amps. Refer to the latest edition of the National Electric Code or in Canada the Canadian electrical Code and local codes to determine correct wire sizing.

ELECTRICAL DATA FOR MULTI-SOURCE POWER SUPPLY: 208/230-3-60

Air Handler Models	Heater Models ¹	Heater Amps @240V	Min. Circuit Ampacity				MOP. ²			
			208V		230V		208V		230V	
			Circuit				Circuit			
			1st ³	2nd	1st ³	2nd	1st ³	2nd	1st ³	2nd
MVC12B	6HK46502025	46.2	31.3	25.0	33.3	27.6	35	25	35	30
MVC16C	6HK46502025	46.2	34.1	25.0	36.4	27.6	35	25	40	30
MVC20D	6HK46502025	46.2	34.1	25.0	36.4	27.6	35	25	40	30
	6HK46502525	57.7	40.4	31.3	43.3	34.6	45	35	45	35

- The 20kW and 25kW heater models (6HK46502025 and 6HK46502525) come with service disconnects standard.
- MOP = Maximum Overcurrent Protection device; must be HACR type circuit breaker or time delay fuse. The 1st circuit includes blower motor amps. Refer to the latest edition of the National Electric Code or in Canada the Canadian electrical Code and local codes to determine correct wire sizing.

POWER WIRING - LINE CONNECTIONS

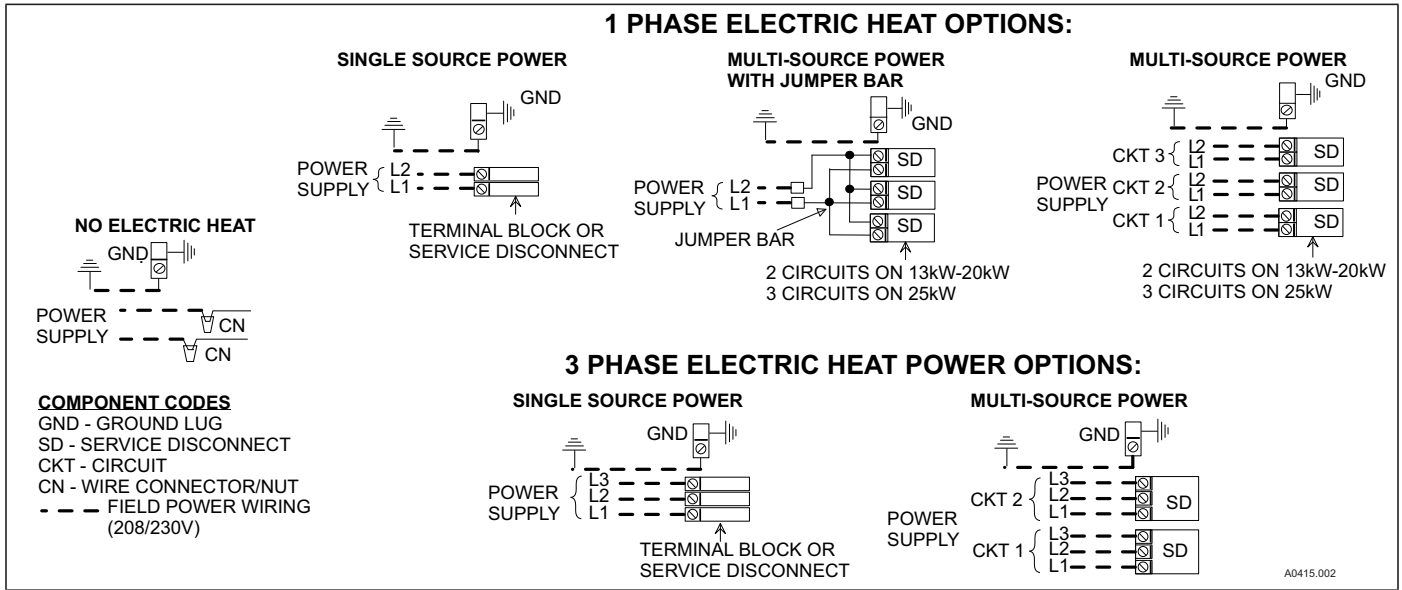

ACCESSORIES

Refer to Price Manual for specific model numbers where not shown.

TXV Kits - Air handlers are shipped with “Flex-coils” without a factory installed metering device. For added flexibility, an R-22 or R-410A TXV or orifice can be field installed to meet your refrigerant choice. All kits are bolt-on and require no brazing to install.

Electric Heaters - 6HK models shown under electrical data include sequential operation and temperature dual limit switches for safe, efficient operation. Service disconnects are provided where shown.

SINGLE SOURCE POWER ACCESSORIES (SINGLE PHASE)	
S1-02435670000	For heat kits with 2 service disconnects.
S1-02435671000	For heat kits with 3 service disconnects.
SINGLE SOURCE POWER ACCESSORY (THREE PHASE)	
S1-32436041000	Contains a terminal block and wiring to connect service disconnects together.

Bottom Rack Filter Kit - The filter frame accessory allows installation of an external air handler filter in an upflow application, a downflow application, or a horizontal application (refer to the following illustration/table for Filter Rack Dimensions).

Combustible Floor Base Accessory - If an electric heat accessory which is rated for greater than zero clearance to combustible surfaces is installed in these air handlers in the downflow operating positions on a combustible floor, one of the following combustible floor base accessory models is required: S1-1FB1917, S1-1FB1921, S1-1FB1924.

Breaker Moisture Seal Accessory - A clear service disconnect moisture barrier seals the service disconnect(s) from humidity and dust. The flexibility of the clear cover allows service disconnects to be turned ON or OFF without removing the cover. The cover firmly attaches to the access panel around the service disconnects with the use of double backed adhesive tape. To ensure that moisture or dust does not contaminate service disconnects, an S1-02435672000 Cover Breaker Moisture Seal may be ordered.

Thermostat - Compatible thermostat controls are available through accessory sourcing. For optimum performance, these outdoor units are fully compatible with our York touch screen thermostat with proprietary (patent-pending) hexagon interface. For more information, see the thermostat section of the Product Equipment Catalog.

FILTER RACK DIMENSIONS

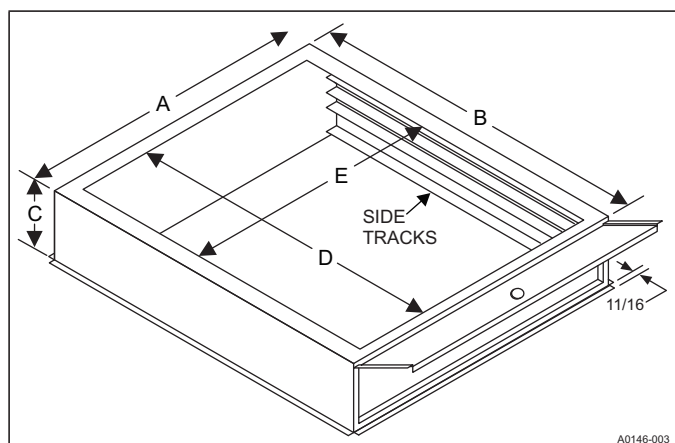

Galvanized Models	A	B	C	D	E	Filter Size
1BR01117	17.50	21.56	4.00	18.63	14.25	16 x 20 x 1 or 2
1BR01121	21.00	21.56	4.00	18.63	17.75	20 x 20 x 1 or 2
1BR01124	24.50	21.56	4.00	18.63	21.25	20 x 24 x 1 or 2

Note: Filters - Not supplied with kit.

LIMITATIONS

These units must be wired and installed in accordance with all national and local safety codes.

Voltage limits are as follows:

Air Handler Voltage	¹ Normal Operating Voltage Range
208/230-1-60	187-253

1. Rated in accordance with ARI Standard 110, utilization range "A".

Airflow must be within the minimum and maximum limits approved for electric heat, indoor coils and outdoor units.

TYPICAL APPLICATIONS

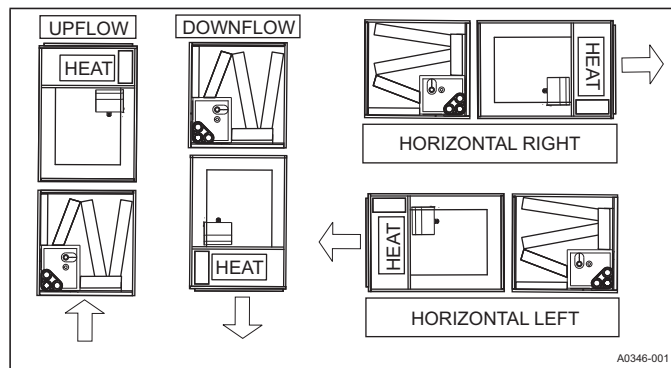

COMBUSTIBLE FLOOR BASE ACCESSORY

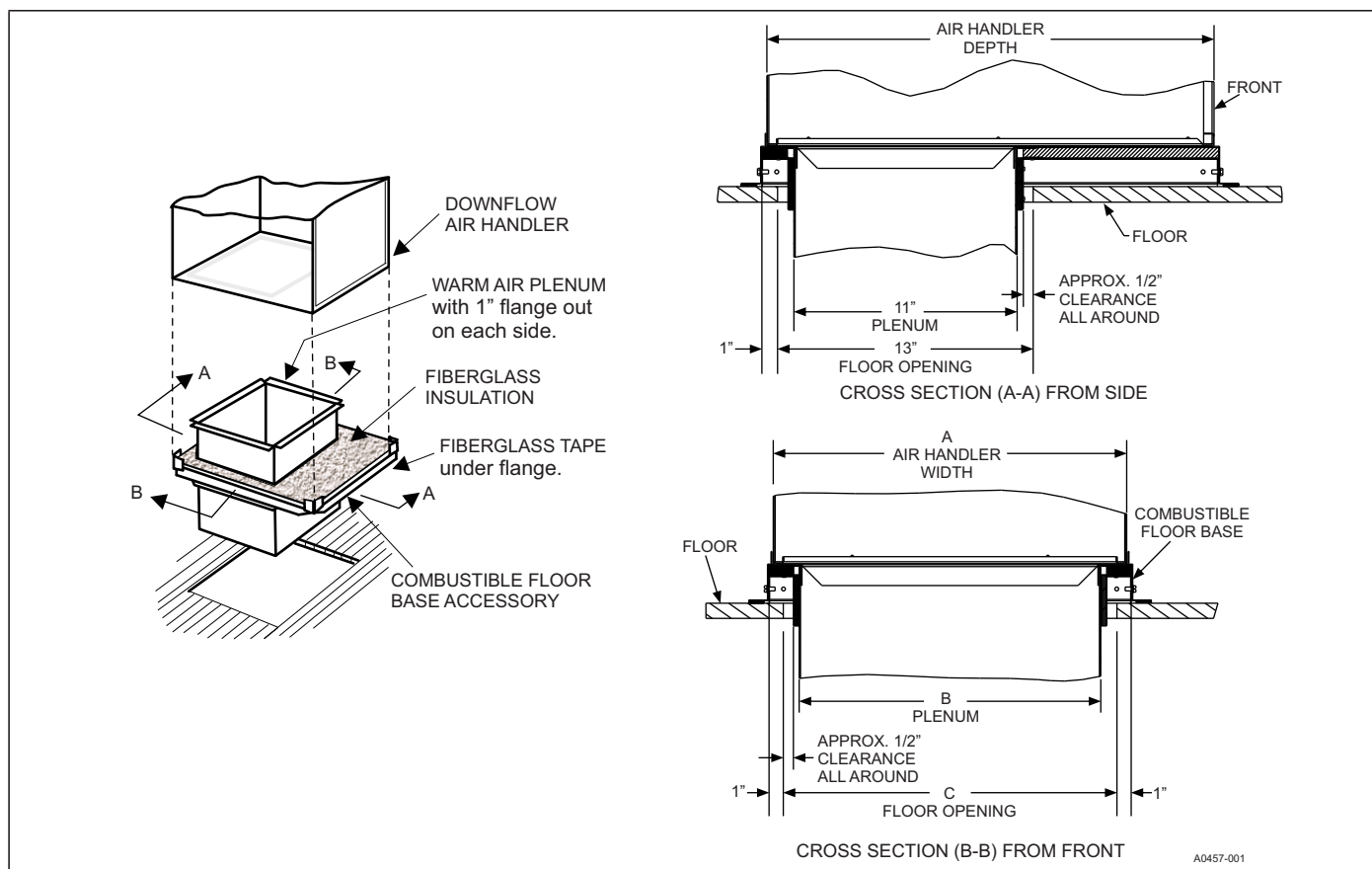

Floor Base Models	Used with	Dimensions		
		A	B	C
1FB1917	MVC08B, MVC12B	19.9	14.0	14.9
1FB1921	MVC16C	23.4	17.5	18.4
1FB1924	MVC14D, MVC20D	26.9	21.0	21.9

TYPICAL THERMOSTAT CONNECTION

Cooling Models with and without Electric Heat Wiring

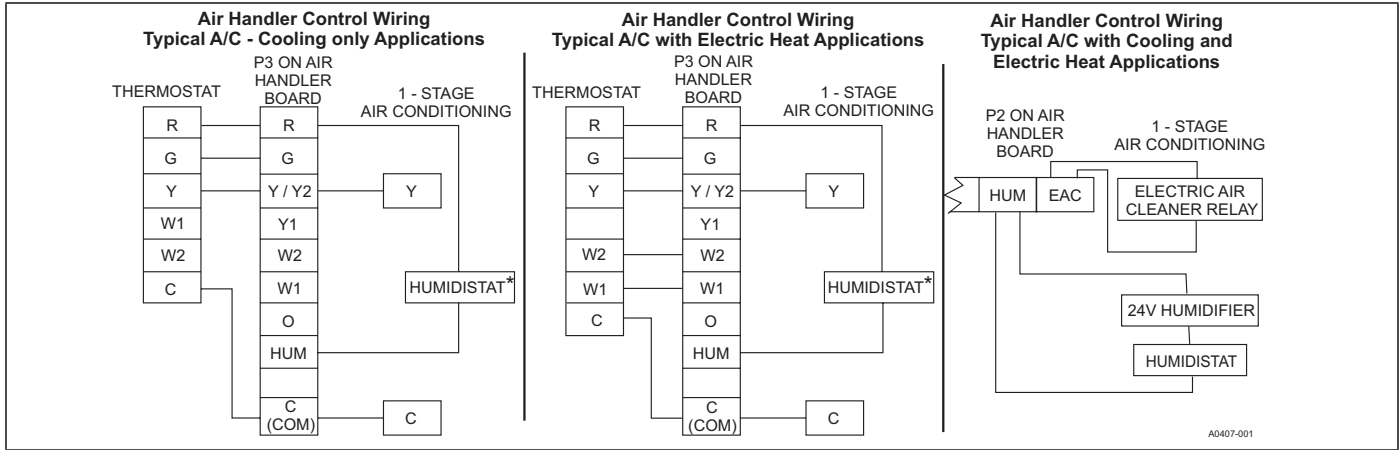

* Optional dehumidification humidistat switch contacts open on humidity rise.

NOTES:

1. "Y/Y2" Thermostat wire must be connected for full CFM and applications requiring 60 second blower off delay for SEER enhancement.
2. Move HUM STAT jumper on air handler control board to YES position if humidistat is used.
3. For heat pump applications - set AC/HP jumper on air handler control board to the HP position.

Two-Stage Heat Pump Wiring

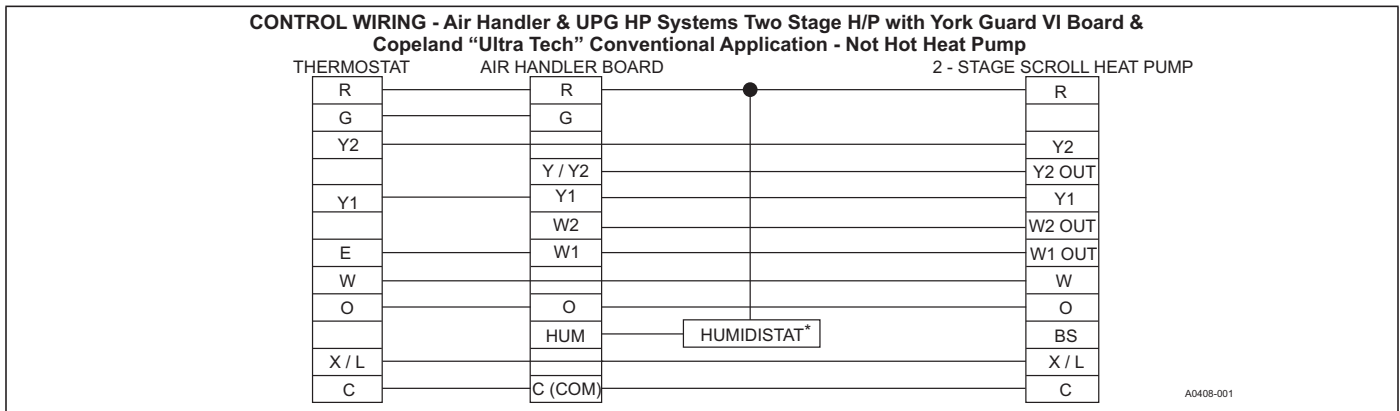

* Optional dehumidification humidistat switch contacts open on humidity rise.

NOTES:

1. "Y/Y2" Thermostat wire must be connected for full CFM and applications requiring 60 second blower off delay for SEER enhancement.
2. Remove humidistat jumper on air handler control board.
3. For heat pump applications - set AC/HP jumper on air handler control board to the HP position.

Air Handler with Communicating AC or HP

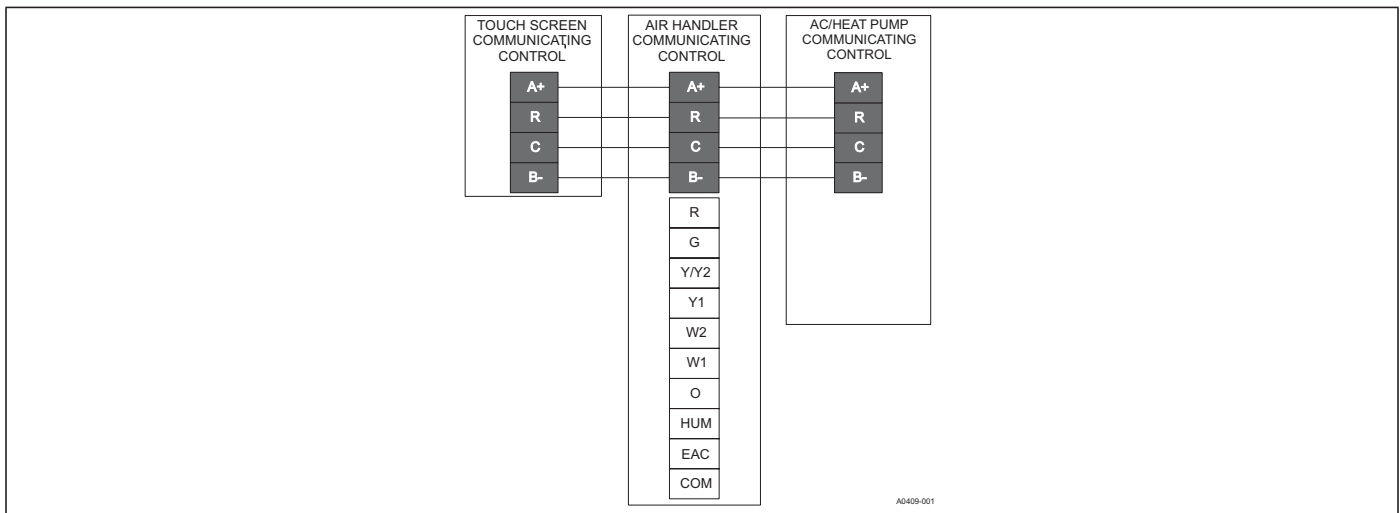

AIR FLOW DATA - CFM¹

High/Low Speed Cooling and Heat Pump CFM											
CFM											
Cool Tap	ADJ Tap ²	MVC08B		MVC12B		MVC14D		MVC16C		MVC20D	
		High	Low	High	Low	High	Low	High	Low	High	Low
A	B	1022	562	1350	878	1425	1037	1760	1144	1935	1316
B	B	795	437	1238	804	1425	910	1540	1001	1772	1152
A	A	900	495	1200	780	1425	926	1600	1040	1800	1170
B	A	700	385	1100	715	1250	813	1400	910	1575	1024
A	C	783	431	1050	683	1268	824	1424	926	1665	1082
C	B	766	421	1125	731	1344	874	1320	858	1491	969
B	C	609	335	963	626	1113	723	1246	810	1457	947
D	B	568	312	900	585	1120	728	1100	715	1350	878
C	A	675	371	1000	650	1200	780	1200	780	1325	861
D	A	500	275	800	520	1000	650	1000	650	1200	780
C	C	587	323	875	569	1068	694	1068	694	1226	797
D	C	435	239	700	455	890	579	890	579	1110	722
m3/min											
Cool Tap	ADJ Tap ²	MVC08B		MVC12B		MVC14D		MVC16C		MVC20D	
		High	Low	High	Low	High	Low	High	Low	High	Low
A	B	28.9	15.9	38.2	24.8	40.4	29.4	49.8	32.4	54.8	37.3
B	B	22.5	12.4	35.0	22.8	40.4	25.8	43.6	28.3	50.2	32.6
A	A	25.5	14.0	34.0	22.1	40.4	26.2	45.3	29.4	51.0	33.1
B	A	19.8	10.9	31.1	20.2	35.4	23.0	39.6	25.8	44.6	29.0
A	C	22.2	12.2	29.7	19.3	35.9	23.3	40.3	26.2	47.1	30.6
C	B	21.7	11.9	31.9	20.7	38.1	24.7	37.4	24.3	42.2	27.4
B	C	17.2	9.5	27.3	17.7	31.5	20.5	35.3	22.9	41.3	26.8
D	B	16.1	8.8	25.5	16.6	31.7	20.6	31.1	20.2	38.2	24.8
C	A	19.1	10.5	28.3	18.4	34.0	22.1	34.0	22.1	37.5	24.4
D	A	14.2	7.8	22.7	14.7	28.3	18.4	28.3	18.4	34.0	22.1
C	C	16.6	9.1	24.8	16.1	30.2	19.7	30.2	19.7	34.7	22.6
D	C	12.3	6.8	19.8	12.9	25.2	16.4	25.2	16.4	31.4	20.4
High/Low Speed Heat CFM											
CFM											
Heat Tap	ADJ Tap ²	MVC08B		MVC12B		MVC14D		MVC16C		MVC20D	
		High	Low	High	Low	High	Low	High	Low	High	Low
A	Any	1025	980	1225	1020	1425	1050	1650	1200	1825	1150
B	Any	960	960	1150	950	1325	1000	1550	1150	1775	1050
C	Any	725	725	950	750	1125	950	1375	1050	1570	1000
D	Any	580	580	725	725	900	900	1150	1000	1375	950
m3/min											
Heat Tap	ADJ Tap ²	MVC08B		MVC12B		MVC14D		MVC16C		MVC20D	
		High	Low	High	Low	High	Low	High	Low	High	Low
A	Any	29.0	27.8	34.7	28.9	40.4	29.7	46.7	34.0	51.7	32.6
B	Any	27.2	27.2	32.6	26.9	37.5	28.3	43.9	32.6	50.3	29.7
C	Any	20.5	20.5	26.9	21.2	31.9	26.9	38.9	29.7	44.5	28.3
D	Any	16.4	16.4	20.5	20.5	25.5	25.5	32.6	28.3	38.9	26.9

1. Air handler units have been tested to UL 1995 / CSA 22.2 No.236 standards up to 0.50" WC. external static pressure.

Dry coil conditions only, tested without filters.

For optimal performance, external static pressures of 0.2" to 0.5" are recommended. Heating applications tested at 0.50" w.c. esp. Above 0.5" CFM is reduced by 2% per 0.1" increase in static.

2. The ADJ tap does not affect the HEAT tap setting.

Low speed cooling used only with two stage outdoor units. Speed is preset to 65% of high speed.

Dehumidification speed is 85% of jumper selected COOL tap and ADJUST tap.

At some settings, LOW COOL and/or LOW HEAT airflow may be lower than what is required to operate an airflow switch on certain models of electronic air cleaners.

Consult the instructions for the electronic air cleaner for further details.

Airflow (CFM) indicator light (LED2) flashes once for every 100 CFM (i.e.: 12 flashes is 1200 CFM) - blinks are approximate +/- 10% of actual CFM.

NOTES